

255 Welter Drive
Monticello, IA 52310

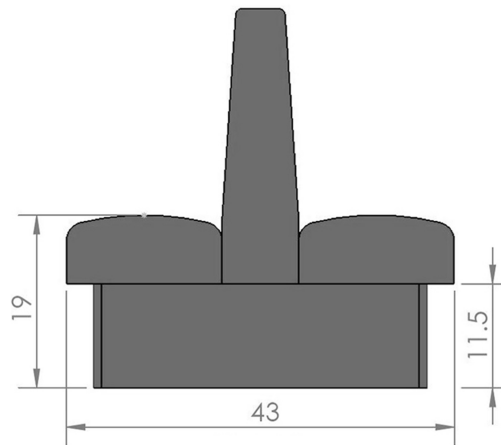

P: 877.465.4344
F: 877.465.4042
www.oakstreetmfg.com

READY TO SHIP (RTS) AMBROSE VINYL/UPHOLSTERED BOOTHS

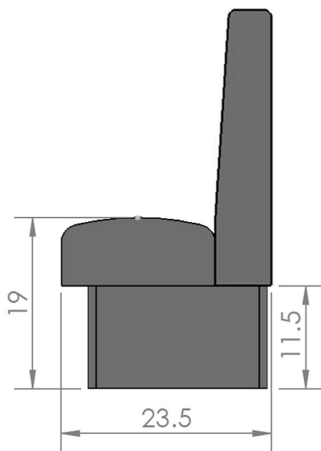

- Stocked in our black in-house vinyl in 48" x 42" singles & doubles. Other sizes and colors available made-to-order.
- Top stitched seams with updated pillow back.
- Fully sculpted, springless seat - no springs to break, sag or squeak.
- Seats are reversible & removable.
- Both ends are finished for endless reconfiguration possibilities.
- Seat backs are screwed, not glued or stapled, to base - providing added strength.
- One step black vinyl toe kick glued with forEVA glue process with poly protective corners for long term wearability.